

4" MANUAL STRAINER

In-Line Flow Type DH

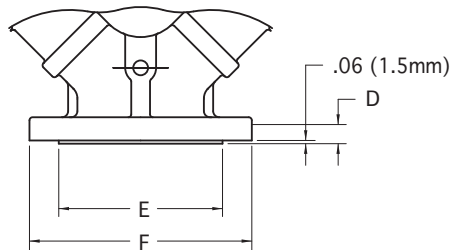

FOR ANSI FLANGE CLASS 250, 150, 300 & DIN

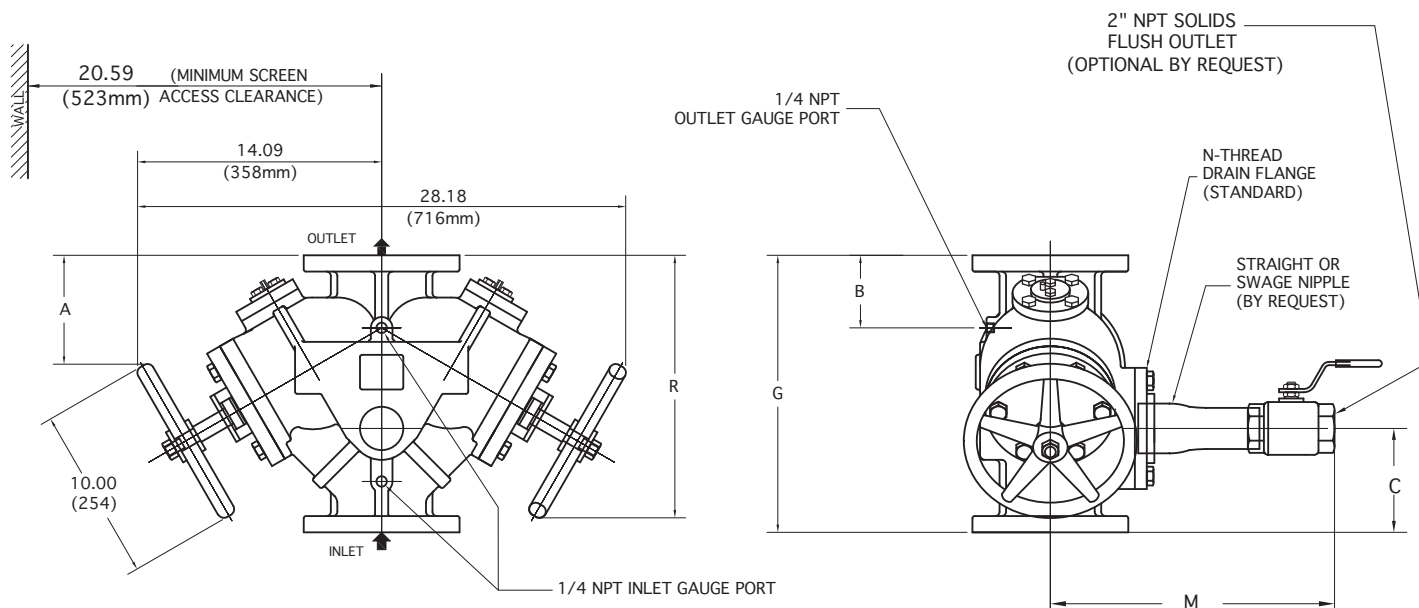
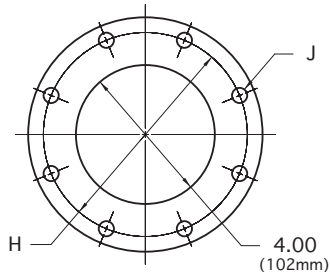

TOP & BOTTOM FLANGES

FLANGE SIZE		A	B	C	D	E	F	G	H	J (HOLES)		M	R	N DRAIN FLANGE SIZE	APPROX. WEIGHT
										No.	DIA.				
ANSI class 125 CAST IRON	INCH	6.29	4.19	6.00	.94	NA	9.00	16.00	7.50	8	.75	16.41	15.16	2-1/2" NPT	170 lb
	MM	160	106	152	24	NA	229	406	191	8	19	416	385		77 kg
ANSI class 250 CAST IRON	INCH	6.60	4.50	6.31	1.25	6.94	10.00	16.62	7.88	8	.88	12.54	15.47	2" NPT	190 lb
	MM	168	114	160	32	176	254	422	200	8	22	318	393		86 kg
ANSI class 150 CAST STEEL & STAINLESS STEEL	INCH	6.29	4.19	6.00	.94	6.19	9.00	16.00	7.50	8	.75	13.79	15.16	2" NPT	180 lb
	MM	160	106	152	24	157	229	406	191	8	19	350	385		82 kg
ANSI class 300 CAST STEEL & STAINLESS STEEL	INCH	6.60	4.50	6.31	1.25	6.94	10.00	16.62	7.88	8	.88	14.10	15.47	2" NPT	200 lb
	MM	168	114	160	32	176	254	422	200	8	22	358	393		90 kg
100 DN 10 DIN 2501	INCH	6.29	4.19	6.00	.94	6.19	9.00	16.00	7.09	8	.71	13.79	15.16	2" NPT	180 lb
	MM	160	106	152	24	157	229	406	180	8	18	350	385		82 kg
100 DN 16 DIN 2501	INCH	6.60	4.50	6.31	1.25	6.94	10.00	16.62	7.09	8	.71	14.10	15.47	2" NPT	200 lb
	MM	168	114	160	32	176	254	422	180	8	18	358	393		90 kg

THESE DIMENSIONS ARE FOR REFERENCE ONLY. FOR INSTALLATION PURPOSES, REQUEST CERTIFIED DRAWINGS.