

12" AUTOMATIC STRAINER

In-Line Flow Type DA

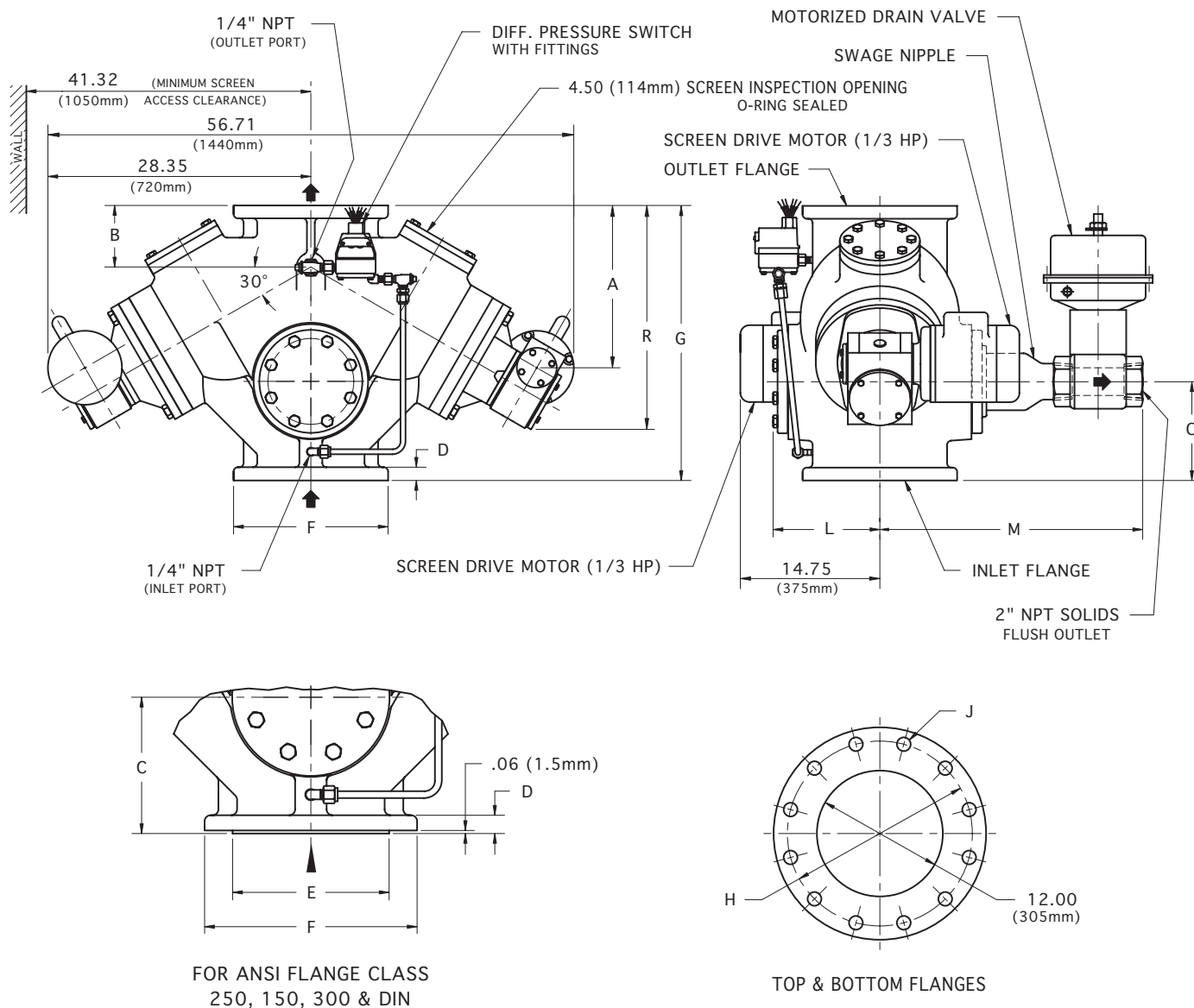

FLANGE SIZE		A	B	C	D	E	F	G	H	J (HOLES)		L	M	R	APPROX. WEIGHT
										No.	DIA.				
ANSI class 125 CAST IRON	INCH	17.59	6.12	10.75	1.25	NA	19.00	31.75	17.00	12	1.00	11.39	24.06	22.41	1525 Lb
	MM	447	156	273	32	NA	483	806	432	12	25	289	611	569	693 Kg
ANSI class 250 CAST IRON	INCH	18.34	6.88	11.50	2.00	16.44	20.50	33.25	17.75	16	1.25	11.78	24.50	23.16	1625 Lb
	MM	466	175	292	51	417	521	844	451	16	32	299	622	588	739 Kg
ANSI class 150 CAST STEEL	INCH	17.59	6.12	10.75	1.25	15.00	19.00	31.75	17.00	12	1.00	11.39	24.06	22.41	1625 Lb
	MM	447	156	273	32	381	483	806	432	12	25	289	611	569	739 Kg
ANSI class 300 CAST STEEL	INCH	18.34	6.88	11.50	2.00	15.00	20.50	33.25	17.75	16	1.25	11.78	24.62	23.16	1725 Lb
	MM	466	175	292	51	381	521	844	451	16	32	299	625	588	784 Kg
300 ND 10 DIN 2501	FLANGE DRILLING (NUMBER AND SIZE OF HOLES AND BOLT CIRCLE) IS IN ACCORDANCE WITH D.I.N. STANDARDS.														
300 ND 16 DIN 2501	ALL OTHER APPLICABLE DIMENSIONS ARE IN ACCORDANCE WITH ANSI STANDARDS ABOVE.														

THESE DIMENSIONS ARE FOR REFERENCE ONLY. FOR INSTALLATION PURPOSES, REQUEST CERTIFIED DRAWINGS.