

# 8" AUTOMATIC STRAINER

## In-Line Flow Type DA

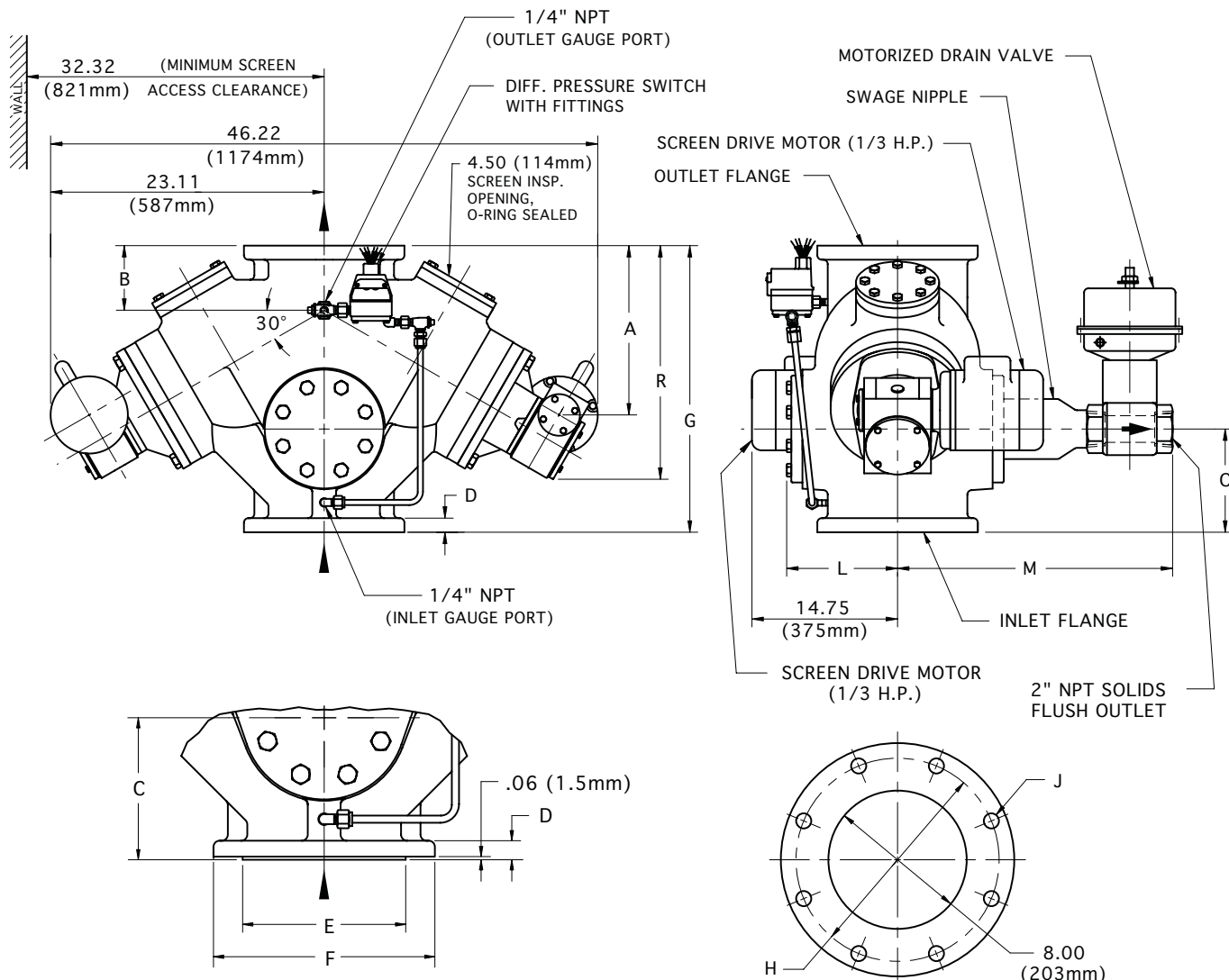

FOR ANSI FLANGE CLASS 250, 150, 300 & DIN

TOP & BOTTOM FLANGES

FLANGE SIZE		A	B	C	D	E	F	G	H	J (HOLES)		M	L	R	APPROX. WEIGHT
										No.	DIA.				
ANSI class 125 CAST IRON	INCH	13.82	5.38	8.62	1.12	NA	13.50	24.00	11.75	8	.88	22.06	9.39	18.62	860 lb.
	MM	351	137	219	29	NA	343	610	298	8	22	560	238	473	391 kg.
ANSI class 250 CAST IRON	INCH	14.32	5.88	9.12	1.62	11.94	15.00	25.00	13.00	12	1.00	22.50	9.78	19.12	910 lb.
	MM	364	149	232	41	303	381	635	330	12	25	572	248	486	414 kg.
ANSI class 150 CAST STEEL	INCH	13.82	5.38	8.62	1.12	10.62	13.50	24.00	11.75	8	.88	22.06	9.39	18.62	910 lb.
	MM	351	137	219	29	270	343	610	298	8	22	560	238	473	414 kg.
ANSI class 300 CAST STEEL	INCH	14.32	5.88	9.12	1.69	10.62	15.00	25.00	13.00	12	1.00	22.62	9.78	19.12	950 lb.
	MM	364	149	232	43	270	381	635	330	12	25	576	248	486	432 kg.
200 ND 10 DIN 2501	FLANGE DRILLING (NUMBER AND SIZE OF HOLES AND BOLT CIRCLE) IS IN ACCORDANCE WITH D.I.N. STANDARDS. ALL OTHER APPLICABLE DIMENSIONS ARE IN ACCORDANCE WITH ANSI STANDARDS ABOVE.														
200 ND 16 DIN 2501															

THESE DIMENSIONS ARE FOR REFERENCE ONLY. FOR INSTALLATION PURPOSES, REQUEST CERTIFIED DRAWINGS.