

# 6" AUTOMATIC STRAINER

## In-Line Flow Type DA

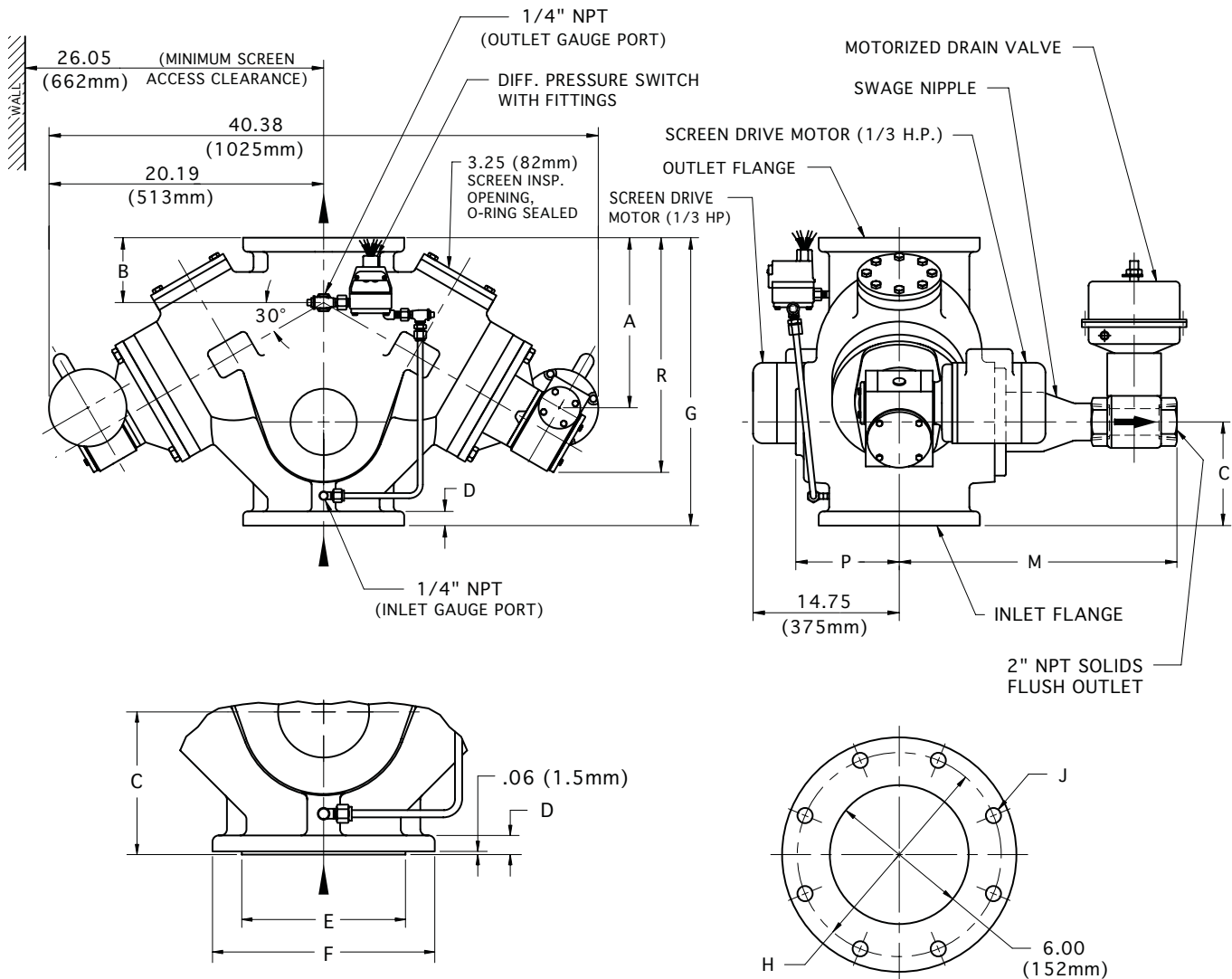

FOR ANSI FLANGE CLASS  
250, 150, 300 & DIN

TOP & BOTTOM FLANGES

FLANGE SIZE		A	B	C	D	E	F	G	H	J (HOLES)		M	P	R	APPROX. WEIGHT
										No.	DIA.				
ANSI class 125 CAST IRON	INCH	11.62	4.88	7.12	1.00	NA	11.00	20.00	9.50	8	.88	19.50	6.12	16.45	560 Lb
	MM	295	124	181	25	NA	279	508	241	8	22	495	155	418	254 Kg
ANSI class 250 CAST IRON	INCH	12.07	5.31	7.56	1.44	9.69	12.50	20.88	10.62	12	.88	19.06	6.12	16.89	590 Lb
	MM	307	135	192	37	246	318	530	270	12	22	484	155	429	268 Kg
ANSI class 150 CAST STEEL	INCH	11.62	4.88	7.12	1.00	8.50	11.00	20.00	9.50	8	.88	19.62	6.12	16.45	585 Lb
	MM	295	124	181	25	216	279	508	241	8	22	498	155	418	266 Kg
ANSI class 300 CAST STEEL	INCH	12.07	5.31	7.56	1.44	8.50	12.50	20.88	10.62	12	.88	19.00	6.00	16.89	615 Lb
	MM	307	135	192	37	216	318	530	270	12	22	483	152	429	279 Kg
150 ND 10 DIN 2501	FLANGE DRILLING (NUMBER AND SIZE OF HOLES AND BOLT CIRCLE) IS IN ACCORDANCE WITH D.I.N. STANDARDS. ALL OTHER APPLICABLE DIMENSIONS ARE IN ACCORDANCE WITH ANSI STANDARDS ABOVE.														
150 ND 16 DIN 2501															

THESE DIMENSIONS ARE FOR REFERENCE ONLY. FOR INSTALLATION PURPOSES, REQUEST CERTIFIED DRAWINGS.