

# 4" AUTOMATIC STRAINER

## In-Line Flow Type DA

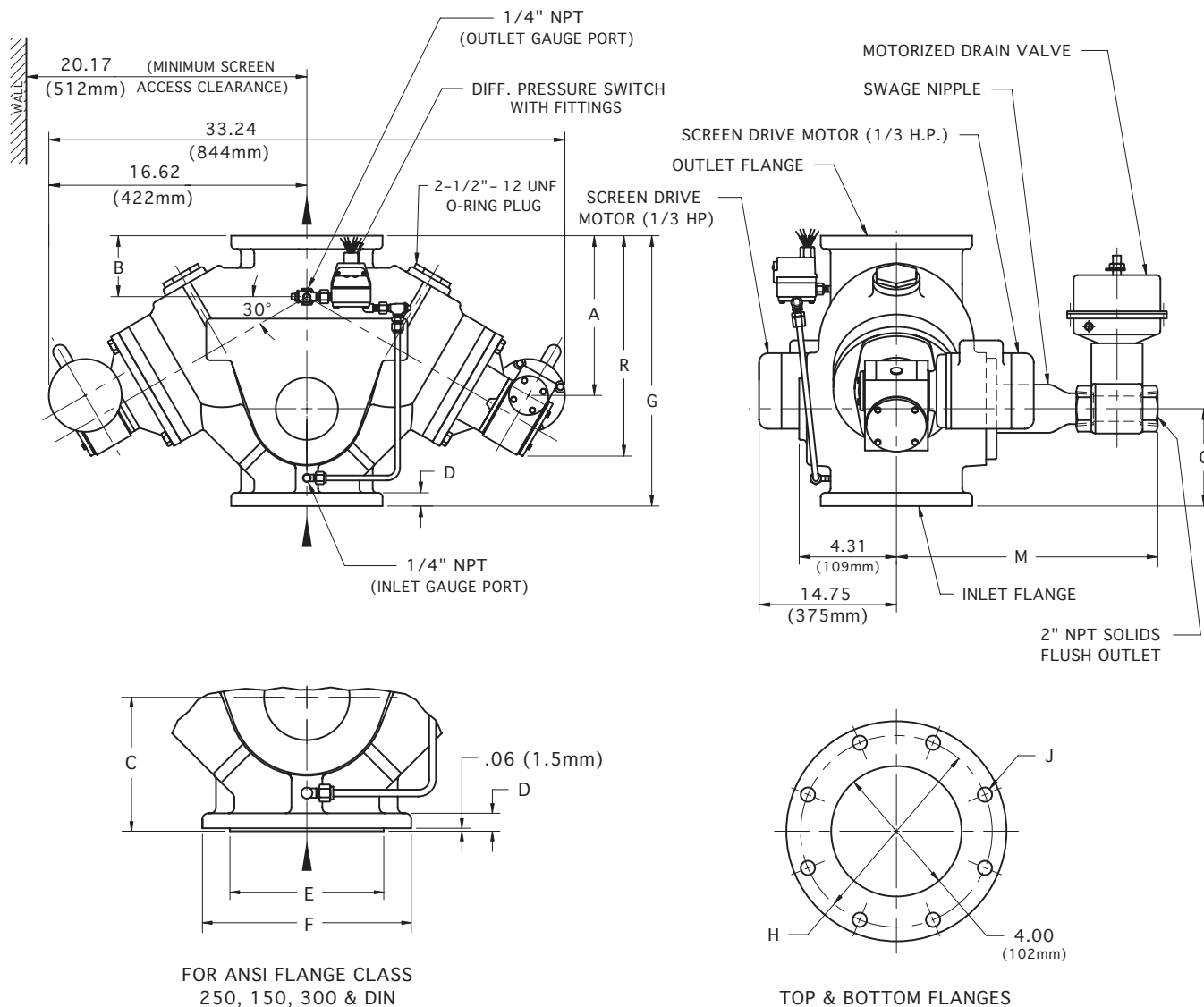

FOR ANSI FLANGE CLASS 250, 150, 300 & DIN

FLANGE SIZE		A	B	C	D	E	F	G	H	J (HOLES) No. DIA.	M	R	APPROX. WEIGHT
ANSI class 125 CAST IRON	INCH	8.91	4.19	6.00	.94	NA	9.00	16.00	7.50	8 .75	16.94	13.73	320 Lb
	MM	226	106	152	24	NA	229	406	191	8 19	430	349	145 Kg
ANSI class 250 CAST IRON	INCH	9.22	4.50	6.31	1.25	6.94	10.00	16.62	7.88	8 .88	14.56	14.04	340 Lb
	MM	234	114	160	32	176	254	422	200	8 22	370	357	154 Kg
ANSI class 150 CAST STEEL	INCH	8.91	4.19	6.00	.94	6.19	9.00	16.00	7.50	8 .75	14.31	13.73	330 Lb
	MM	226	106	152	24	157	229	406	191	8 19	363	349	150 Kg
ANSI class 300 CAST STEEL	INCH	9.22	4.50	6.31	1.25	6.94	10.00	16.62	7.88	8 .88	14.62	14.04	350 Lb
	MM	234	114	160	32	176	254	422	200	8 22	371	357	159 Kg
100 ND 10 DIN 2501	FLANGE DRILLING (NUMBER AND SIZE OF HOLES AND BOLT CIRCLE) IS IN ACCORDANCE WITH D.I.N. STANDARDS.												
100 ND 16 DIN 2501	ALL OTHER APPLICABLE DIMENSIONS ARE IN ACCORDANCE WITH ANSI STANDARDS ABOVE.												

THESE DIMENSIONS ARE FOR REFERENCE ONLY. FOR INSTALLATION PURPOSES, REQUEST CERTIFIED DRAWINGS.