

# 3" AUTOMATIC STRAINER

## Angle Flow Type AA

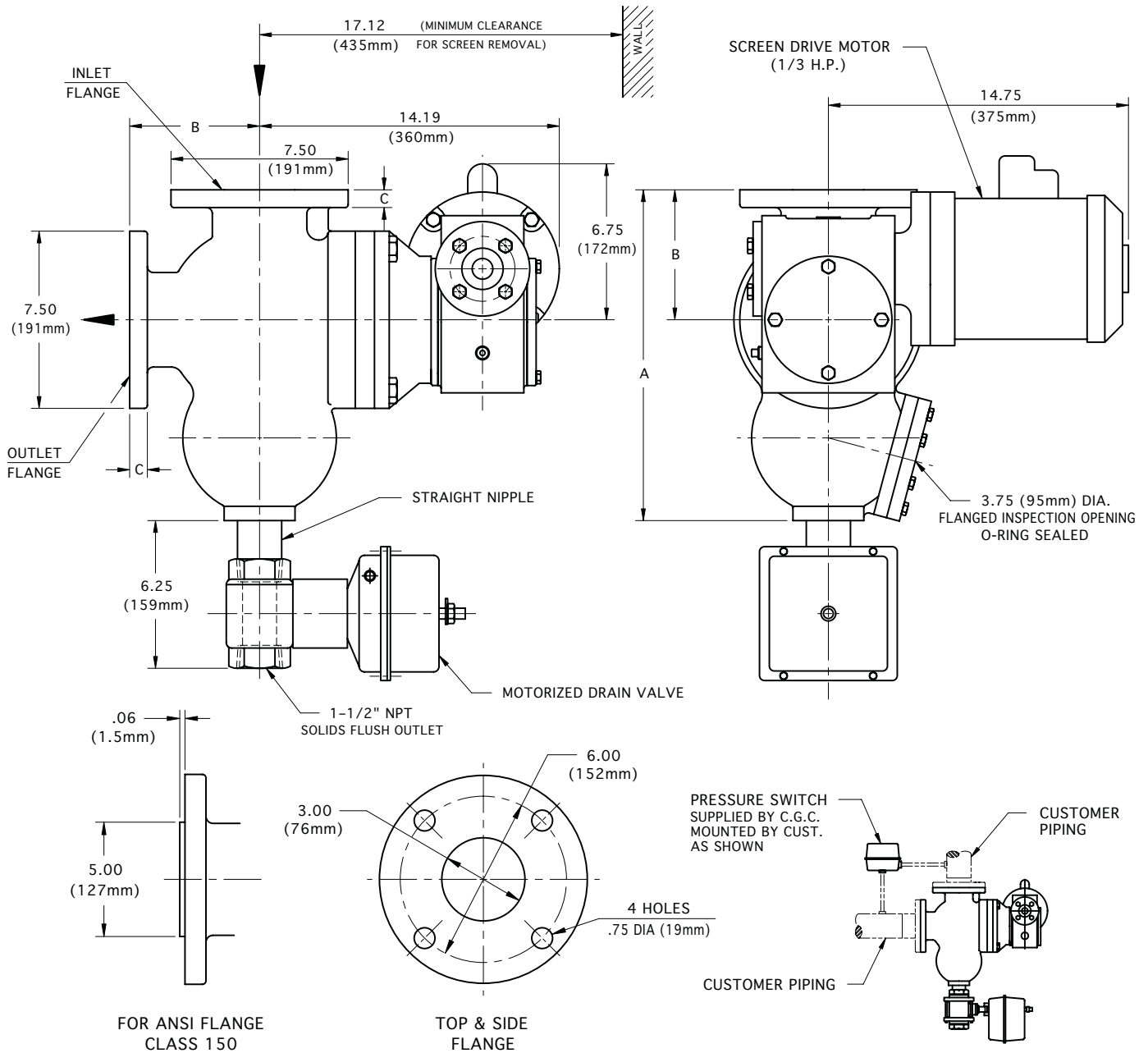

34

FLANGE SIZE		A	B	C	APPROX. WEIGHT
ANSI class 125 CAST IRON	INCH	14.00	5.50	.75	155 Lb
	MM	356	140	19	69 Kg
ANSI class 150 CAST STEEL	INCH	14.19	5.69	.94	163 Lb
	MM	360	144	24	74 Kg
75 ND 10 DIN 2501	FLANGE DRILLING (NUMBER AND SIZE OF HOLES AND BOLT CIRCLE) IS IN ACCORDANCE WITH D.I.N. STANDARDS. ALL OTHER APPLICABLE DIMENSIONS ARE IN ACCORDANCE WITH ANSI STANDARDS ABOVE.				

THESE DIMENSIONS ARE FOR REFERENCE ONLY. FOR INSTALLATION PURPOSES, REQUEST CERTIFIED DRAWINGS.