

10" MANUAL STRAINER

In-Line Flow Type DH

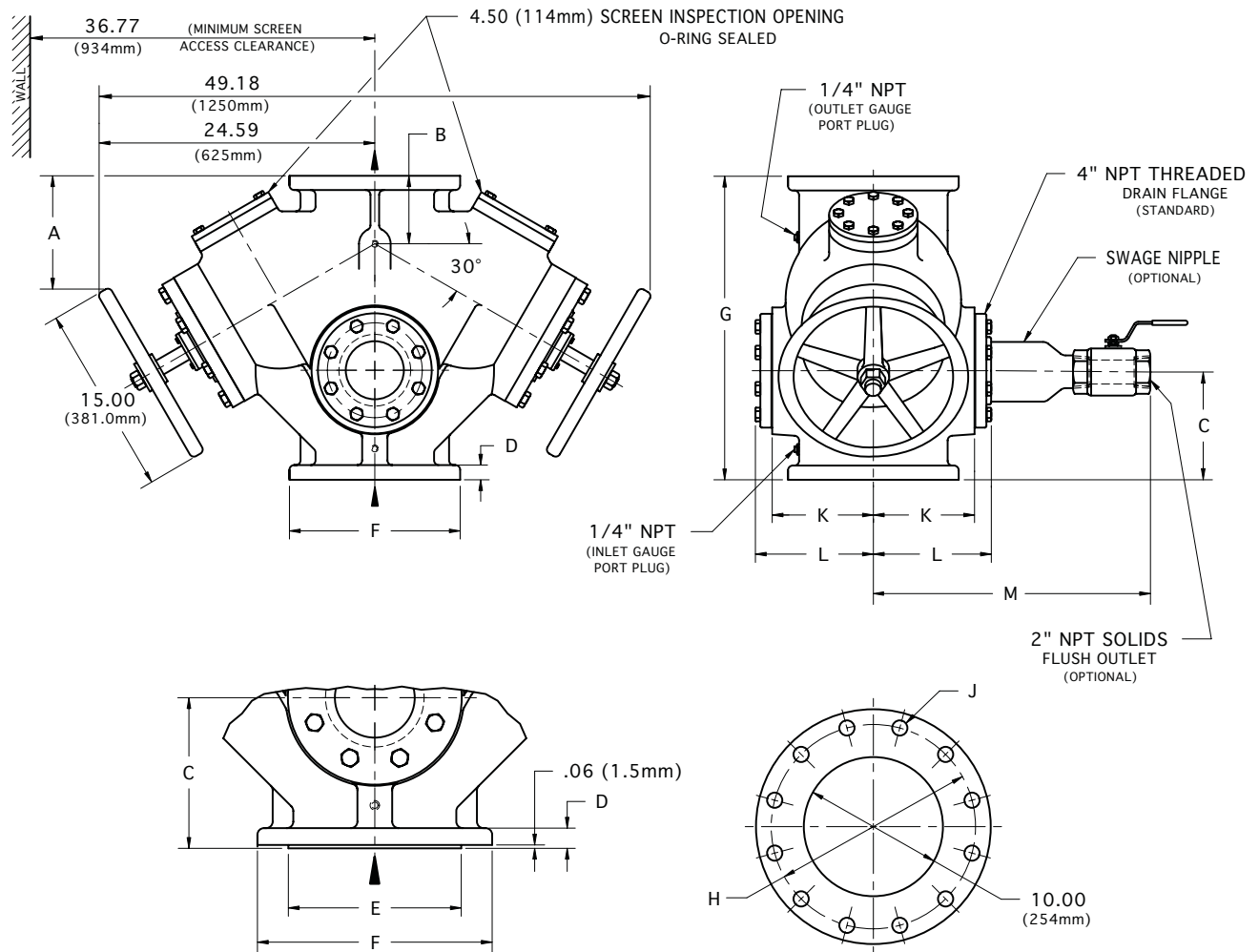

FOR ANSI FLANGE CLASS 250, 150, 300 & DIN

TOP & BOTTOM FLANGES

FLANGE SIZE		A	B	C	D	E	F	G	H	J (HOLES) No.	(HOLES) DIA.	K	L	M	APPROX. WEIGHT
ANSI class 125 CAST IRON	INCH	11.21	5.69	9.50	1.19	NA	16.00	27.50	14.25	12	1.00	9.00	10.39	23.06	950 lb
	MM	285	144	241	30	NA	406	699	362	12	25	229	264	586	432 Kg
ANSI class 250 CAST IRON	INCH	11.90	6.38	10.19	1.88	14.06	17.50	28.88	15.25	16	1.12	9.06	10.84	23.56	1025 lb
	MM	302	162	259	48	357	445	733	387	16	29	230	275	598	466 Kg
ANSI class 150 CAST STEEL	INCH	11.21	5.69	9.50	1.19	12.75	16.00	27.50	14.25	12	1.00	9.00	10.39	23.06	1000 lb
	MM	285	144	241	30	324	406	699	362	12	25	229	264	586	454 Kg
ANSI class 300 CAST STEEL	INCH	11.90	6.38	10.19	1.88	12.75	17.50	28.88	15.25	16	1.12	9.06	10.84	23.69	1075 lb
	MM	302	162	259	48	324	445	733	387	16	29	230	275	602	488 Kg
250 ND 10 DIN 2501	FLANGE DRILLING (NUMBER AND SIZE OF HOLES AND BOLT CIRCLE) IS IN ACCORDANCE WITH D.I.N. STANDARDS. ALL OTHER APPLICABLE DIMENSIONS ARE IN ACCORDANCE WITH ANSI STANDARDS ABOVE.														
250 ND 16 DIN 2501															

THESE DIMENSIONS ARE FOR REFERENCE ONLY. FOR INSTALLATION PURPOSES, REQUEST CERTIFIED DRAWINGS.