

8" MANUAL STRAINER

In-Line Flow Type DH

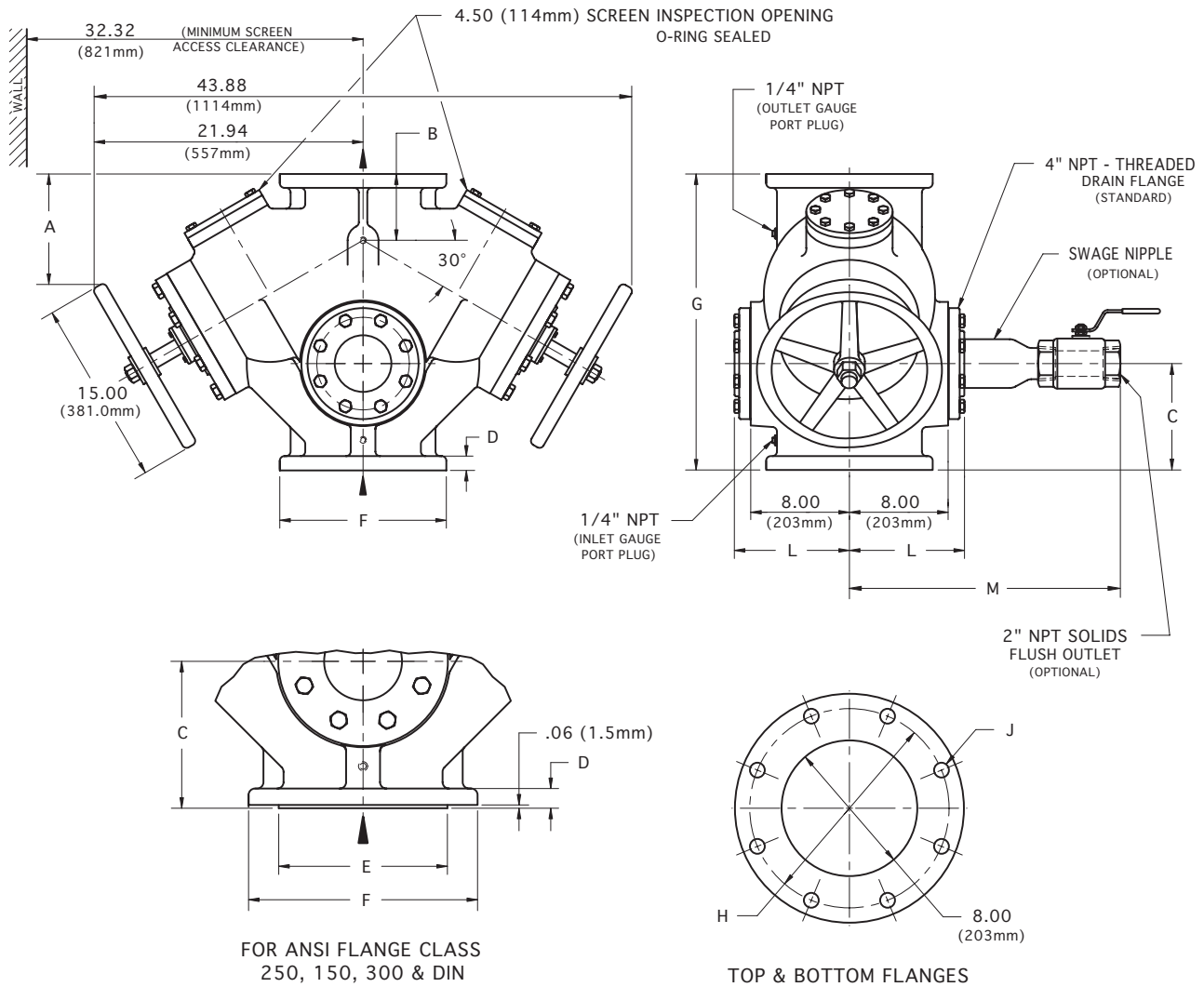

26

FLANGE SIZE		A	B	C	D	E	F	G	H	J (HOLES) No. DIA.	L	M	APPROX. WEIGHT
ANSI class 125 CAST IRON	INCH	8.94	5.38	8.62	1.13	NA	13.50	24.00	11.75	8 .88	9.39	22.06	700 Lb
	MM	277	137	219	29	NA	343	610	298	8 22	238	560	318 Kg
ANSI class 250 CAST IRON	INCH	9.44	5.88	9.12	1.62	11.94	15.00	25.00	13.00	12 1.00	9.78	22.50	750 Lb
	MM	239	149	232	41	503	381	635	330	12 25	248	572	341 Kg
ANSI class 150 CAST STEEL	INCH	8.94	5.38	8.62	1.13	10.62	13.50	24.00	11.75	8 .88	9.39	22.06	750 Lb
	MM	277	137	219	29	270	343	610	298	8 22	238	560	341 Kg
ANSI class 300 CAST STEEL	INCH	9.44	5.88	9.12	1.69	10.62	15.00	25.00	13.00	12 1.00	9.78	22.62	800 Lb
	MM	239	149	232	43	270	381	635	330	12 25	248	575	364 Kg
200 ND 10 DIN 2501	FLANGE DRILLING (NUMBER AND SIZE OF HOLES AND BOLT CIRCLE) IS IN ACCORDANCE WITH D.I.N. STANDARDS.												
200 ND 16 DIN 2501	ALL OTHER APPLICABLE DIMENSIONS ARE IN ACCORDANCE WITH ANSI STANDARDS ABOVE.												

THESE DIMENSIONS ARE FOR REFERENCE ONLY. FOR INSTALLATION PURPOSES, REQUEST CERTIFIED DRAWINGS.