

# 4" MANUAL STRAINER

## In-Line Flow Type DH

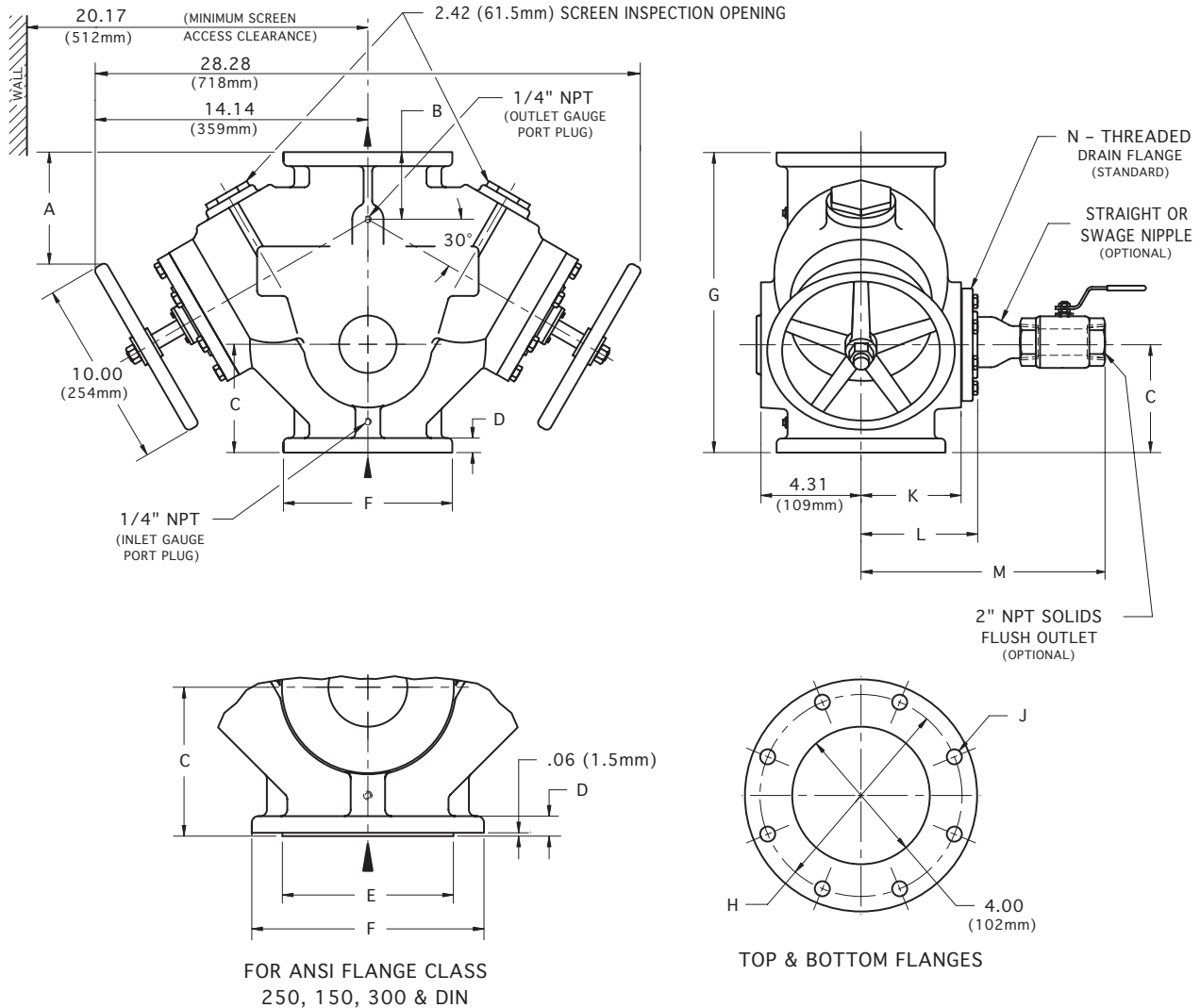

24

FOR ANSI FLANGE CLASS 250, 150, 300 & DIN

TOP & BOTTOM FLANGES

FLANGE SIZE		A	B	C	D	E	F	G	H	J (HOLES) No.	DIA.	K	L	M	'N' DRAIN FLANGE SIZE	APPROX. WEIGHT
ANSI class 125 CAST IRON	INCH	6.22	4.19	6.00	.94	NA	9.00	16.00	7.50	8	.75	4.88	6.02	16.94	2-1/2" NPT	170 Lb
	MM	158	106	152	24	NA	229	406	191	8	19	124	153	430		77 Kg
ANSI class 250 CAST IRON	INCH	6.53	4.50	6.31	1.25	6.94	10.00	16.62	7.88	8	.88	5.12	6.45	14.56	2" NPT	190 Lb
	MM	166	114	160	32	176	254	422	200	8	22	130	164	370		86 Kg
ANSI class 150 CAST STEEL	INCH	6.22	4.19	6.00	.94	6.19	9.00	16.00	7.50	8	.75	5.12	6.33	14.31	2" NPT	180 Lb
	MM	158	106	152	24	157	229	406	191	8	19	130	161	363		82 Kg
ANSI class 300 CAST STEEL	INCH	6.53	4.50	6.31	1.25	6.94	10.00	16.62	7.88	8	.88	5.12	6.45	14.62	2" NPT	200 Lb
	MM	166	114	160	32	176	254	422	200	8	22	130	164	371		90 Kg
100 ND 10 DIN 2501	FLANGE DRILLING (NUMBER AND SIZE OF HOLES AND BOLT CIRCLE) IS IN ACCORDANCE WITH D.I.N. STANDARDS. ALL OTHER APPLICABLE DIMENSIONS ARE IN ACCORDANCE WITH ANSI STANDARDS ABOVE.															
100 ND 16 DIN 2501																

THESE DIMENSIONS ARE FOR REFERENCE ONLY. FOR INSTALLATION PURPOSES, REQUEST CERTIFIED DRAWINGS.