

2-1/2" MANUAL STRAINER

In-Line Flow Type DH

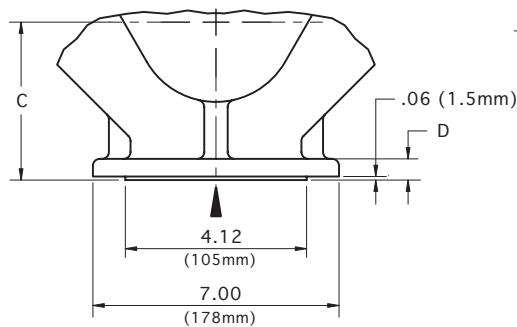

FOR ANSI FLANGE CLASS 150

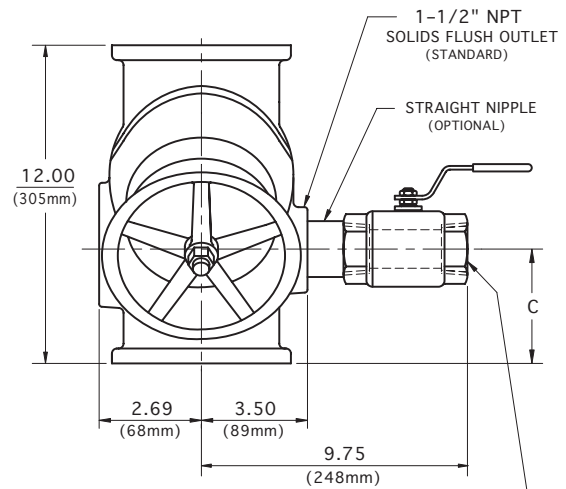
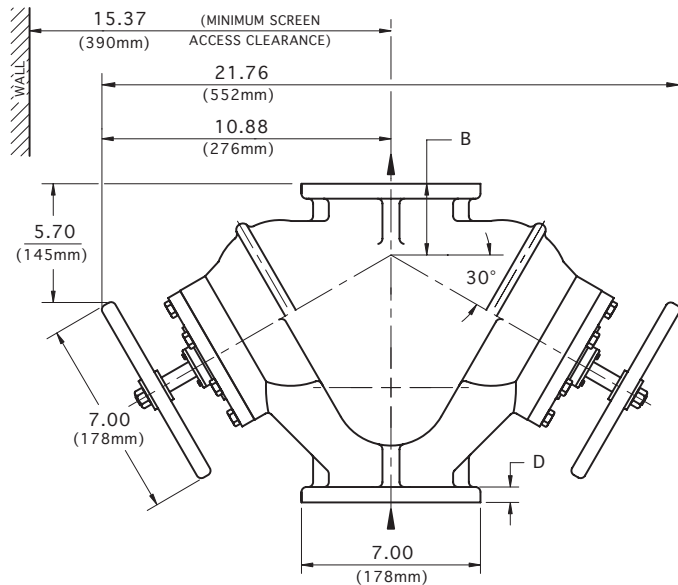
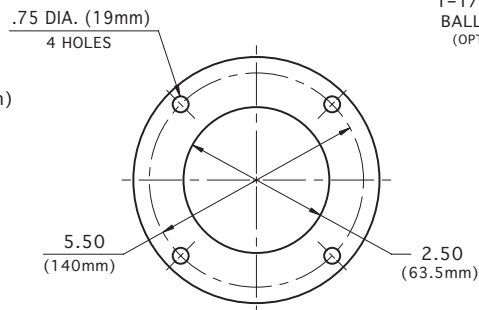

TOP & BOTTOM FLANGES

FLANGE SIZE		B	C	D	APPROX. WEIGHT
ANSI class 125 CAST IRON	INCH	3.50	4.69	.75	100 Lb
	MM	89	119	19	45 Kg
ANSI class 150 CAST STEEL	INCH	3.62	4.81	.88	105 Lb
	MM	92	122	22	48 Kg
65 ND 10 DIN 2501	FLANGE DRILLING (NUMBER AND SIZE OF HOLES AND BOLT CIRCLE) IS IN ACCORDANCE WITH D.I.N. STANDARDS. ALL OTHER APPLICABLE DIMENSIONS ARE IN ACCORDANCE WITH ANSI STANDARDS ABOVE.				

THESE DIMENSIONS ARE FOR REFERENCE ONLY. FOR INSTALLATION PURPOSES, REQUEST CERTIFIED DRAWINGS.