

16" AUTOMATIC STRAINER

In-Line Flow Type QA

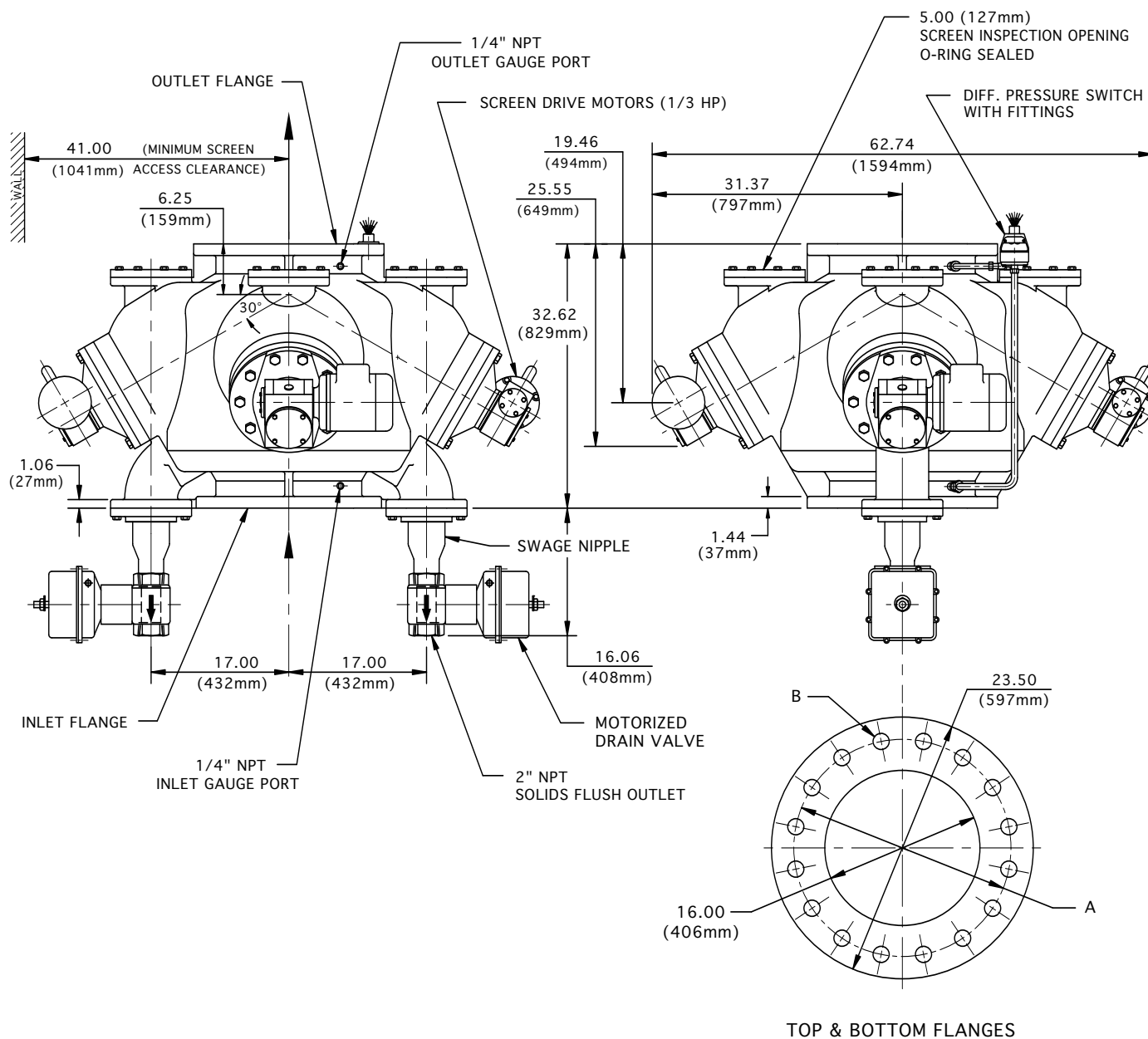

FLANGE SIZE		A	B (HOLES)		APPROX. WEIGHT
			No.	DIA.	
ANSI class 125 Cast Iron & Ductile Iron	INCH	21.25	16	1.12	4600 Lb
	MM	540	16	29	2100 Kg
400 ND 10 DIN 2501	FLANGE DRILLING (NUMBER AND SIZE OF HOLES AND BOLT CIRCLE) IS IN ACCORDANCE WITH D.I.N. STANDARDS. ALL OTHER APPLICABLE DIMENSIONS ARE IN ACCORDANCE WITH ANSI STANDARDS ABOVE.				

THESE DIMENSIONS ARE FOR REFERENCE ONLY. FOR INSTALLATION PURPOSES, REQUEST CERTIFIED DRAWINGS.