

# 14" AUTOMATIC STRAINER

## In-Line Flow Type QA

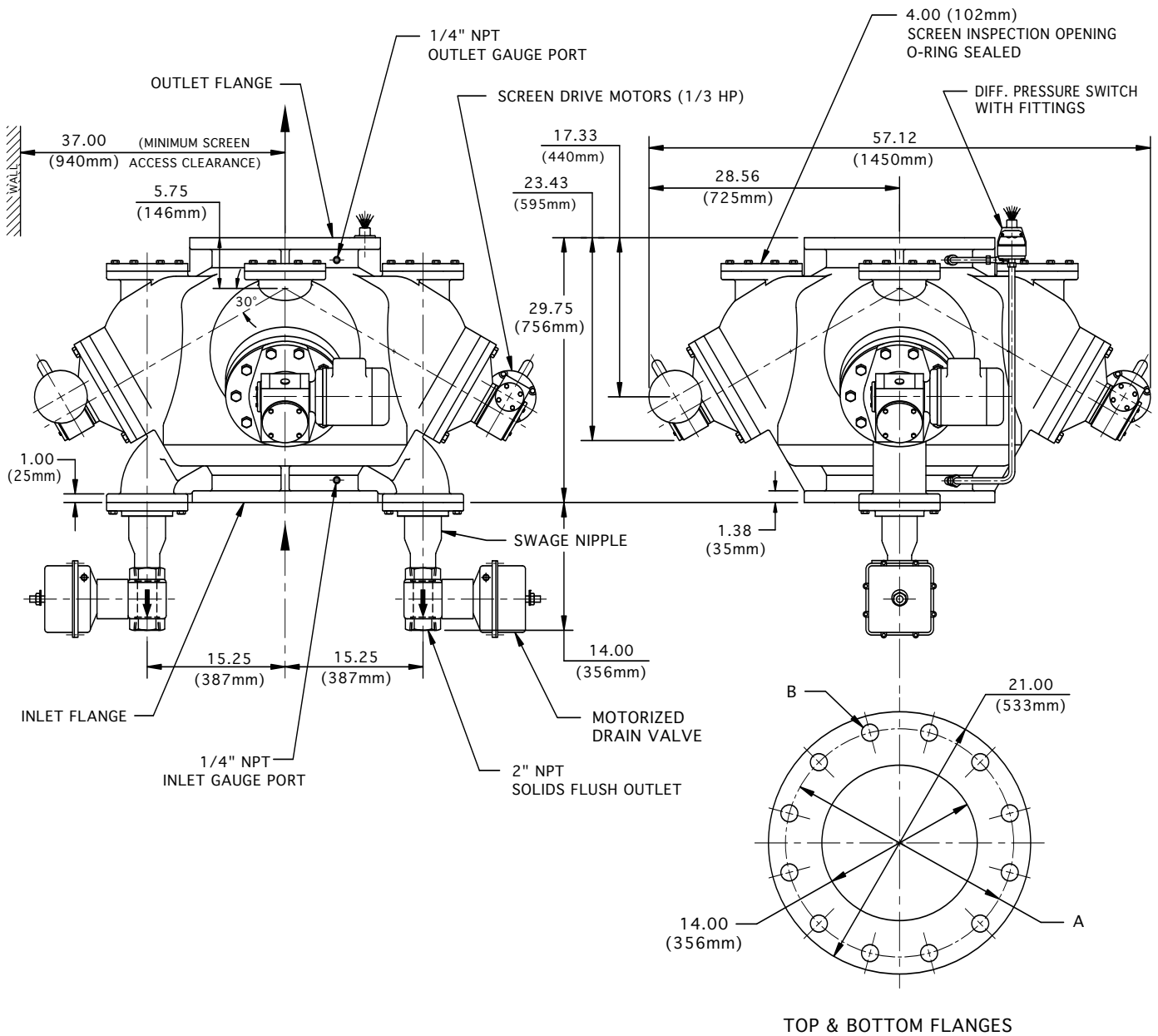

FLANGE SIZE		A	B (HOLES)		APPROX. WEIGHT
			No.	DIA.	
ANSI class 125 Cast Iron & Ductile Iron	INCH	18.75	12	1.12	4000 Lb
	MM	476	12	29	1800 Kg
350 ND 10 DIN 2501	FLANGE DRILLING (NUMBER AND SIZE OF HOLES AND BOLT CIRCLE) IS IN ACCORDANCE WITH D.I.N. STANDARDS. ALL OTHER APPLICABLE DIMENSIONS ARE IN ACCORDANCE WITH ANSI STANDARDS ABOVE.				

THESE DIMENSIONS ARE FOR REFERENCE ONLY. FOR INSTALLATION PURPOSES, REQUEST CERTIFIED DRAWINGS.