

# 3" MANUAL STRAINER

## In-Line Flow Type DH

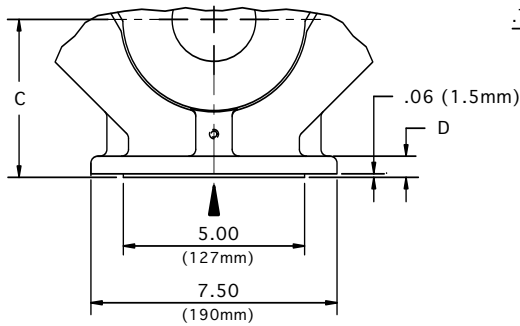

FOR ANSI FLANGE CLASS 150

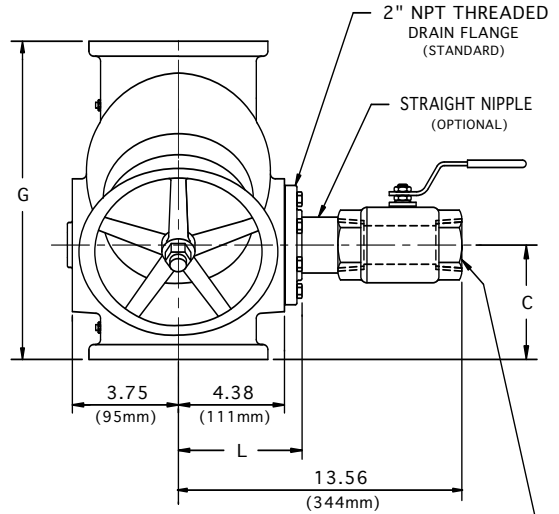
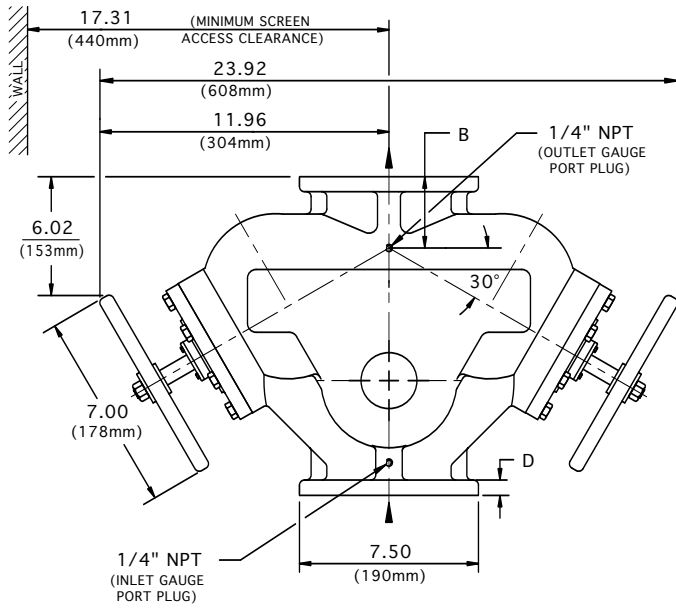
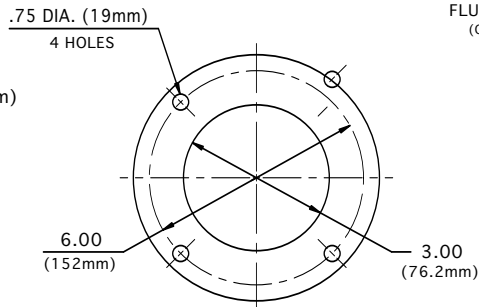

TOP & BOTTOM FLANGES

FLANGE SIZE		B	C	D	G	L	APPROX. WEIGHT
ANSI class 125 Cast Iron & Ductile Iron	INCH	1.88	4.75	.75	13.00	5.45	135 Lb
	MM	48	121	19	330	138	61 Kg
ANSI class 150 Cast Steel	INCH	2.06	4.94	.94	13.38	5.58	145 Lb
	MM	52	125	24	340	142	66 Kg
75 ND 10 DIN 2501	FLANGE DRILLING (NUMBER AND SIZE OF HOLES AND BOLT CIRCLE) IS IN ACCORDANCE WITH D.I.N. STANDARDS.  ALL OTHER APPLICABLE DIMENSIONS ARE IN ACCORDANCE WITH ANSI STANDARDS ABOVE.						
75 ND 16 DIN 2501							

THESE DIMENSIONS ARE FOR REFERENCE ONLY. FOR INSTALLATION PURPOSES, REQUEST CERTIFIED DRAWINGS.