

12" MANUAL STRAINER

In-Line Flow Type DH

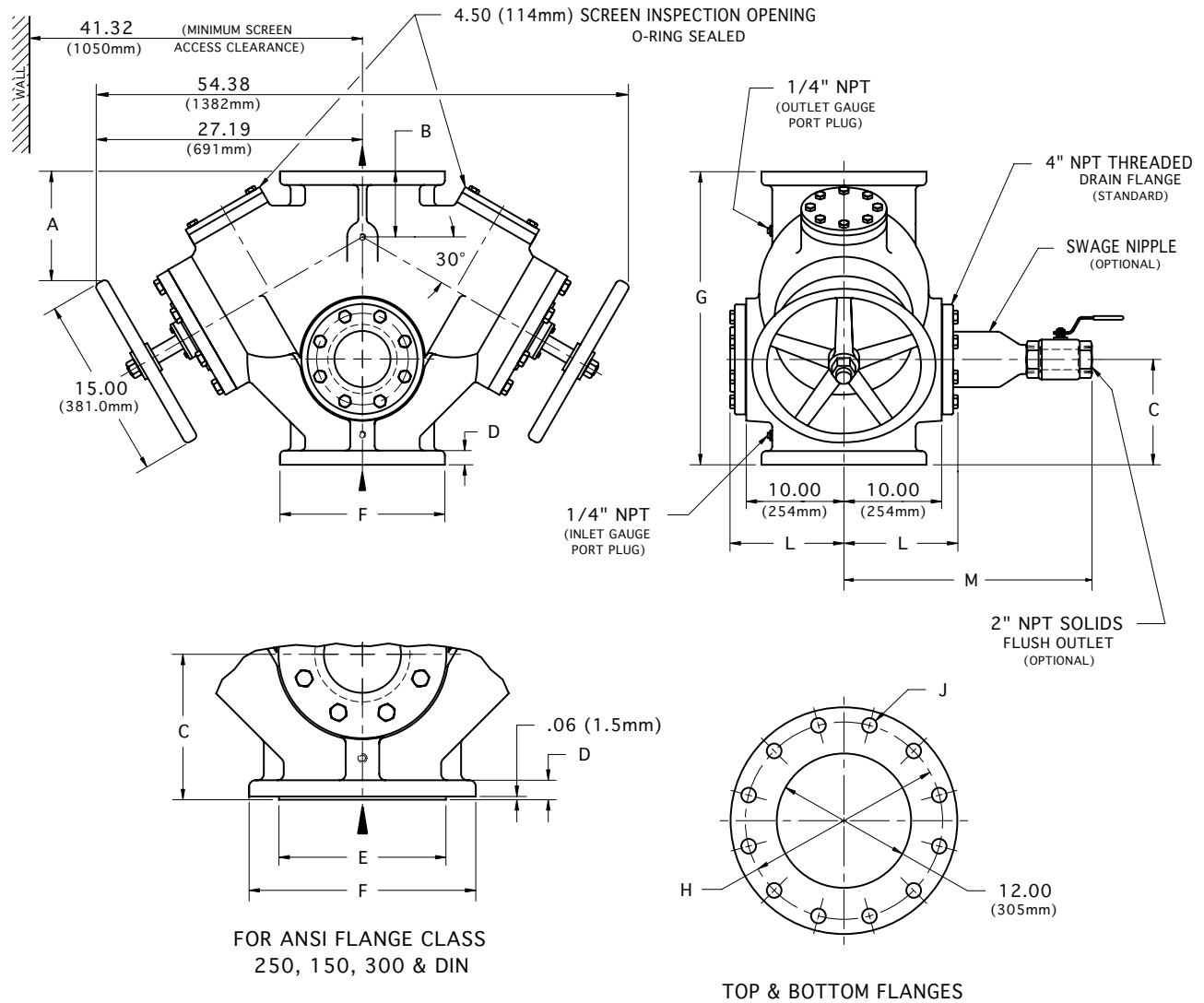

FLANGE SIZE		A	B	C	D	E	F	G	H	J (HOLES)		L	M	APPROX. WEIGHT
										No.	DIA.			
ANSI class 125 Cast Iron & Ductile Iron	INCH	12.71	6.12	10.75	1.25	NA	19.00	31.75	17.00	12	1.00	11.39	24.06	1350 Lb
	MM	323	156	273	32	NA	483	806	432	12	25	289	611	614 Kg
ANSI class 250 Cast Iron & Ductile Iron	INCH	13.46	6.88	11.50	2.00	16.44	20.50	33.25	17.75	16	1.25	11.78	24.50	1450 Lb
	MM	342	175	292	51	417	521	844	451	16	32	299	622	659 Kg
ANSI class 150 Cast Steel	INCH	12.71	6.12	10.75	1.25	15.00	19.00	31.75	17.00	12	1.00	11.39	24.06	1450 Lb
	MM	323	156	273	32	381	483	806	432	12	25	289	611	659 Kg
ANSI class 300 Cast Steel	INCH	13.46	6.88	11.50	2.00	15.00	20.50	33.25	17.75	16	1.25	11.78	24.62	1550 Lb
	MM	342	175	292	51	381	521	844	451	16	32	299	625	704 Kg
300 ND 10 DIN 2501	FLANGE DRILLING (NUMBER AND SIZE OF HOLES AND BOLT CIRCLE) IS IN ACCORDANCE WITH D.I.N. STANDARDS.													
300 ND 16 DIN 2501	ALL OTHER APPLICABLE DIMENSIONS ARE IN ACCORDANCE WITH ANSI STANDARDS ABOVE.													

THESE DIMENSIONS ARE FOR REFERENCE ONLY. FOR INSTALLATION PURPOSES, REQUEST CERTIFIED DRAWINGS.