

# 12" MANUAL STRAINER

## In-Line Flow Type DH

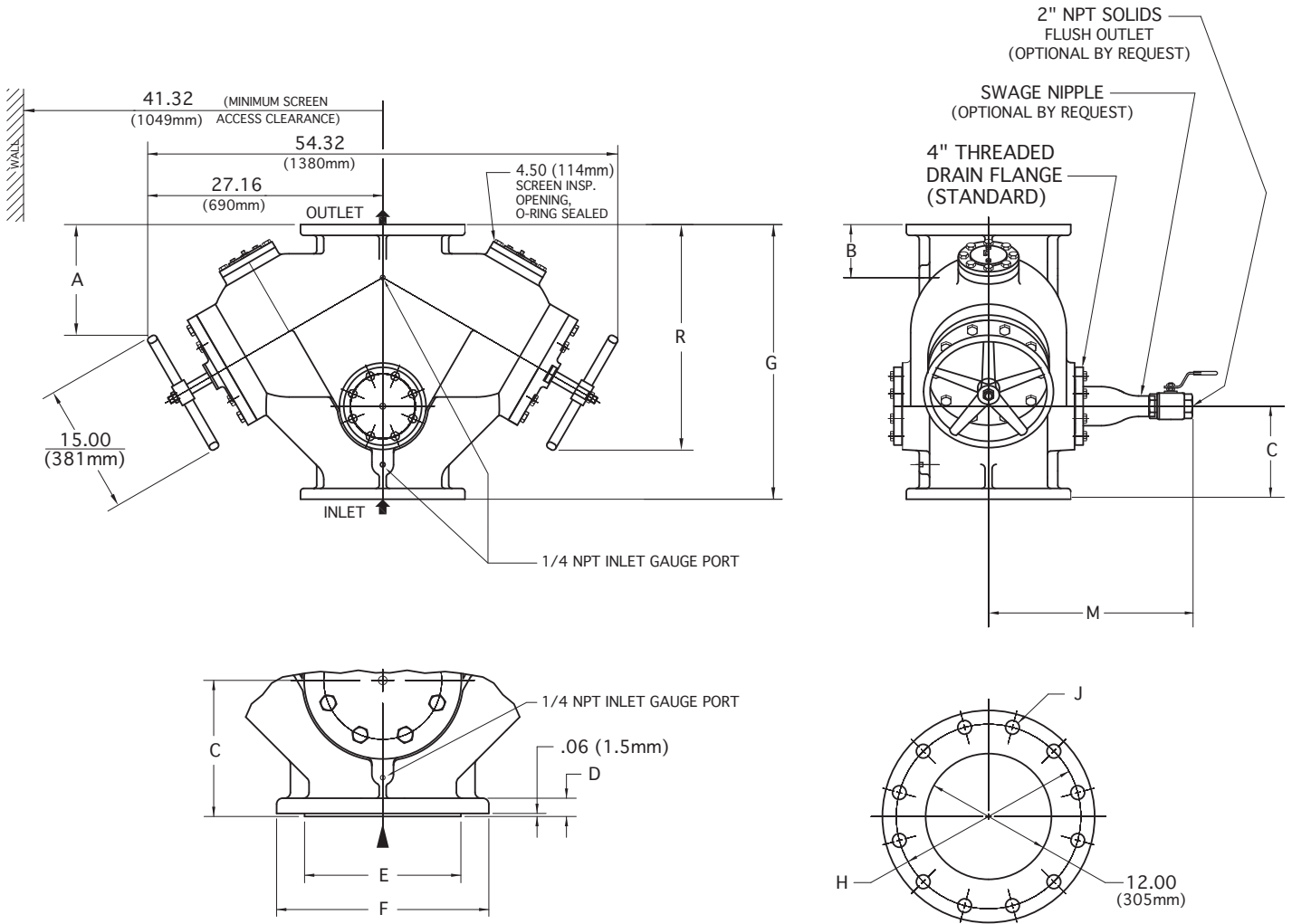

FOR ANSI FLANGE CLASS  
250, 150, 300 & DIN

TOP & BOTTOM FLANGES

FLANGE SIZE		A	B	C	D	E	F	G	H	J (HOLES) No.	DIA.	M	R	APPROX. WEIGHT
ANSI class 125 CAST IRON	INCH	12.80	6.12	10.75	1.25	NA	19.00	31.75	17.00	12	1.00	23.55	26.07	1350 lb
	MM	325	156	273	32	NA	483	806	432	12	25	598	662	614 kg
ANSI class 250 CAST IRON	INCH	13.55	6.88	11.50	2.00	16.44	20.50	33.25	17.75	16	1.25	24.00	26.82	1450 lb
	MM	344	175	292	51	417	521	844	451	16	32	609	681	659 kg
ANSI class 150 CAST STEEL & STAINLESS STEEL	INCH	12.80	6.12	10.75	1.25	15.00	19.00	31.75	17.00	12	1.00	23.55	26.07	1450 lb
	MM	325	156	273	32	381	483	806	432	12	25	598	662	659 kg
ANSI class 300 CAST STEEL & STAINLESS STEEL	INCH	13.55	6.88	11.50	2.00	16.44	20.50	33.25	17.75	16	1.25	24.12	26.82	1550 lb
	MM	344	175	292	51	417	521	844	451	16	32	612	681	704 kg
300 DN 10 DIN 2501	INCH	12.80	6.12	10.75	1.25	15.00	19.00	31.75	15.75	12	.87	23.55	26.07	1450 lb
	MM	325	156	273	32	381	483	806	400	12	22	598	662	659 kg
300 DN 16 DIN 2501	INCH	13.55	6.88	11.50	2.00	16.44	20.50	33.25	16.14	12	1.02	24.12	26.82	1550 lb
	MM	344	175	292	51	417	521	844	410	12	26	612	681	704 kg

THESE DIMENSIONS ARE FOR REFERENCE ONLY. FOR INSTALLATION PURPOSES, REQUEST CERTIFIED DRAWINGS.